

Hazard Warnings

Hazard warnings in this manual indicate potential harm to the user or the product. For the person interacting with the product, the level of risk includes consequences ranging from slight, up to lethal injuries. As for the product, disobeying the warnings may cause damage to the equipment and/or void the warranty. Therefore, said warnings are made apparent to instruct and warn the user, which precautions have to be made prior to performing any actions described in this manual. The user must read and be familiar with the manual, before performing any tasks as described in this manual.

Hazard warnings in this manual are presented in these three forms:

WARNING: These warning notices refer to personal safety. Failure to obey these notices could result in personal injury or death.



WARNING

CAUTION: General precautions must be made. Failure to obey these notices could result in personal injury and/or equipment damage.



CAUTION

NOTE: Directs the user's attention to essential information.

(ex)(r)AB3/5 explosion drawing and spare parts list

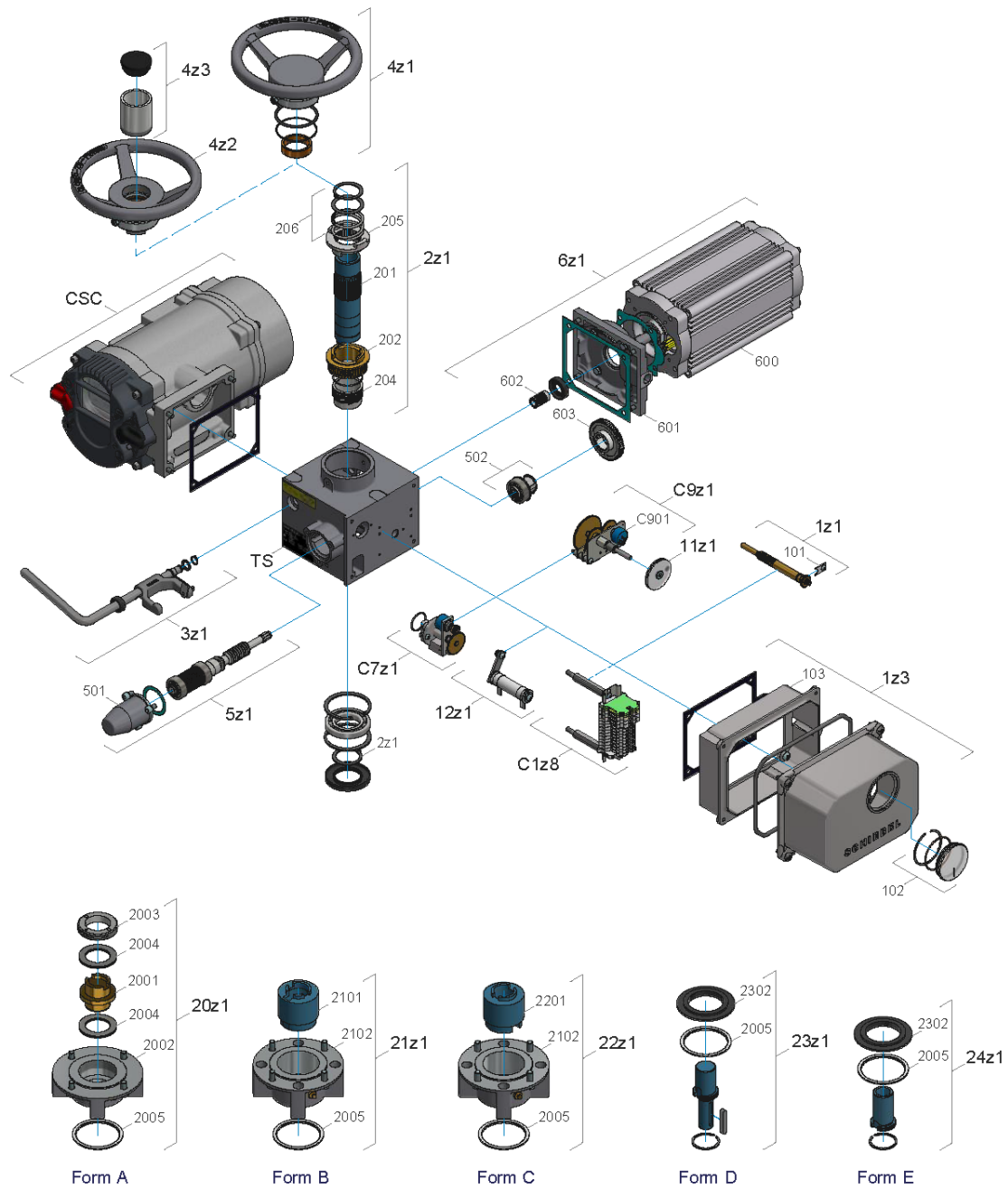

CAUTION: When ordering spare parts, you **must** provide the **serial number** (see type shield).
 Use only original spare parts supplied by SCHIEBEL. Using other parts will render the warranty void.
 Illustrations may differ from actual spare parts.



Asm.	No.	Description
1z1		Helical cut pinion gear with bracket
	101	Pinion gear bracket
1z3		Signalling unit cover with sight glass
	102	Sight glass
	103	Signalling unit frame with O-ring and flat seal
C1z8		Terminal block CSC Ex
2z1		Output shaft
	201	Output shaft
	202	Worm gear
	204	Helical gear
	205	Coupling ring
	206	Spring assembly
3z1		Manual lever
4z1		Handwheel
4z2		Handwheel SpA
4z3		Spindle cover
5z1		Worm shaft
	501	Bearing cover
	502	Hub
6z1		Entire motor
	600	Motor
	601	Motor flange
	602	Motor pinion
	603	Plastic gearwheel
C7z1		Torque unit
C9z1		Teletransmission gear
	C901	Potentiometer 1000Ω
11z1		Mechanical position indicator
12z1		Heater
TS		Type plate
CSC		Smartcon control unit (see page ??)

Asm.	No.	Description
20z1		Output form "A" G0/F10 assembly
	2001	Threaded spindle nut
	2002	Flange "A"
	2003	Ring nut
	2004	Bearing assembly
	2005	Centering ring F10
21z1		Output form "B" G0/F10 assembly
	2101	Std "B" socket
	2102	Std flange "B"
	2005	Centering ring F10
22z1		Output form "C" G0/F10 assembly
	2201	Std "C" claw coupling
	2102	Std flange "B"
	2005	Centering ring F10
23z1		Std output form "D" G0/F10 assembly
	2302	Centering ring G0
	2005	Centering ring F10
24z1		Std output form "E" G0/F10 assembly
	2302	Centering ring G0
	2005	Centering ring F10

CSC.V1.2 explosion drawing and spare parts list

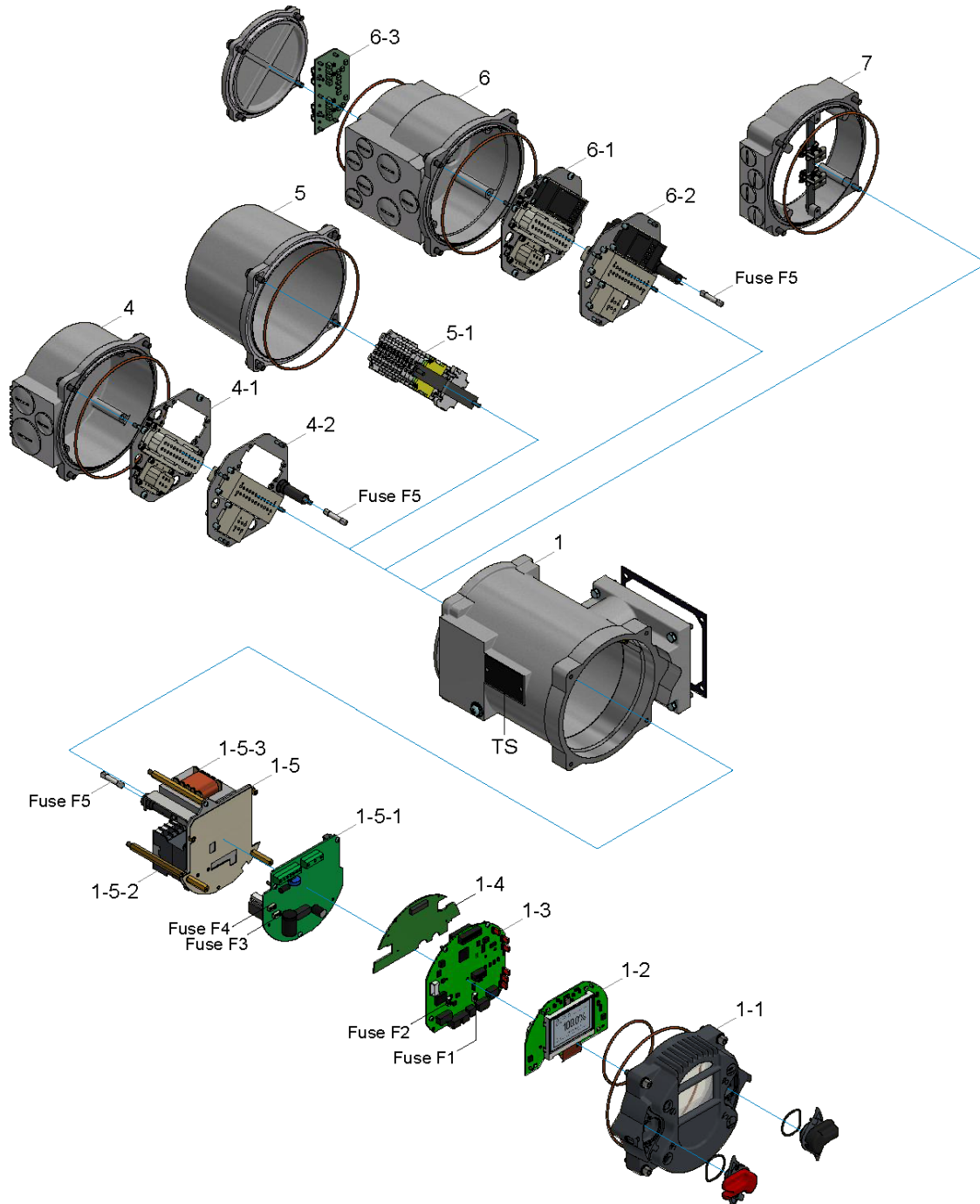

CAUTION: When ordering spare parts, you **must** provide the **serial number** (see type shield).
Use only original spare parts supplied by SCHIEBEL. Using other parts will render the warranty void.
Illustrations may differ from actual spare parts.



CAUTION

No.	Description
1-1	Enclosure
1-1	Control unit cover
1-2	Display board
1-3	Logic board
Fuse-F1	Micro fuse 1A
Fuse-F2	Micro fuse 4A
1-4	Expansion board (bus, relay)
1-5	Supply unit assembly
1-5-1	Base A board
Fuse-F3	Micro fuse 1A
Fuse-F4	Micro fuse 500mA
1-5-2	Reversing contactor
1-5-3	Transformer 230-500V
Fuse-F5	Fuse 125mA T
4	Plug cover
4-1	Connector's panel customer side (socket)
4-2	Connector's panel actuator side (pins) 400V
5	Terminal box cover
5-1	Terminal block cover
6	Entire bus plug cover with connectors and circuit board
6-1	Bus connector's panel customer side (socket)
6-2	Bus connector's panel actuator side (pins) 400V
6-3	Bus connection board
7	Additional ring Bus (Ex)
TS	Type plate